



# Speed-Feed® Universal 400 LH/RH Trimmer Head

P/N 99944200907

Installation and Loading Instructions

### Package Contents:

1 Speed-Feed® 400 LH/RH Universal Mount Trimmer Head (K)

#### Bushings

- (F) 1 - 8mm x 1.25mm LH Bushing (Red)
- (G) 1 - 10mm x 1.0mm LH Bushing (Green)
- (E) 1 - 10mm x 1.25mm LH Bushing (Gold)
- (J) 1 - 10mm x 1.25 LH Long Bushing (Silver)
- (N) 1 - 3/8-24 RH Bushing (Black)

#### Mounting Studs

- (H) 1 - 7mm x 10mm (LH) Mounting Stud (Gold)
- (I) 1 - 8mm x 10mm (LH) Mounting Stud (Silver)
- (O) 1 - 8mm x 3/8-24 (RH) Mounting Stud (Black)

#### Core

- (P) 1 - White RH Core

#### Spacer

- (M) 1 - Reversible Nylon Spacer w/20/25/38 mm Recesses

### Trimmer Head Installation

1. Insert locking tool (A) into gear case to lock output shaft (B). Remove existing cutting attachment (C) from unit following manufacturer's instructions.

**IMPORTANT:** Your unit must be equipped with a debris shield including a line cutter that will cut line to length when trimmer line is advanced.

2. Install or reuse unit manufacturer's gear case base plate (D). Base plate must support trimmer head and allow it to rotate freely.
3. Select and Install Mounting Hardware

Use the **Speed-Feed® Application Chart** provided to identify the bushing or bushing and mounting stud combination needed for your model.

**IMPORTANT: For Echo SRM units only.** Check debris shield on unit for "R" mark between cutoff blade screws.

- a. Units with "R" mark – Echo line head will fit on unit as is - go to Step 6.
- b. Units without "R" mark – Remove short bushing (E) from Echo line head and replace with long bushing (J) and use spacer (M).

**NOTE:** If your brand or model number is not listed, match the existing mounting hardware from your model with Echo mounting studs and/or bushings to determine the correct parts needed. If you need help, visit [www.echo-usa.com](http://www.echo-usa.com), or call the Consumer Product Support Department at 1-800-432-3246 from 8:30 am to 4:30 pm (Central Time) Monday through Friday.

**NOTE:** Gold bushing (E) (used with LH1, LH2, LH6) is preinstalled in trimmer head. Black bushing (N) (used with RH 1 and RH 2) is preinstalled in white core (P). If required, depress locking tabs (T), and open trimmer head (K) to install new parts. Reassemble trimmer head in reverse order of disassembly. Make sure "L" mark is facing away from bushing when replacing spool for LH units. Make sure "R" mark is facing away from bushing for RH units. Trimmer head halves will snap together tightly only if parts are properly assembled.

4. If required, install new mounting stud into threaded hole in gear case output shaft (B). Turn "LH" studs counterclockwise to tighten. Turn "RH" stud clockwise to tighten.
5. If required, place reversible spacer (M) on base plate of gearcase, matching spacer recess to pilot diameter of base plate.

**NOTE:** When spacer is properly matched and installed, there should be no gap between spacer and base plate on gearcase.

### 6. Attach New Trimmer Head (K)

Thread LH trimmer head counterclockwise on to mounting stud or output shaft. Thread RH trimmer head on clockwise. Hand-tighten only.

**Echo SRM Only NOTE:** There should be no gap between spacer and line head after tightening.

**IMPORTANT:** Do not force, otherwise threads will strip and cause permanent damage. Unscrew and confirm correct thread size.

7. Remove locking tool (A) from gear case.
8. If necessary, cut trimmer lines so length does not extend beyond the cut-off blade on debris shield.

### Operation

1. To feed trimmer line, bump bottom of trimmer head against ground while running at normal operating speed.

**Loading Instructions – See Page 4.**

X7672052500

07/13

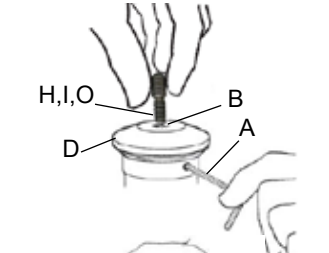
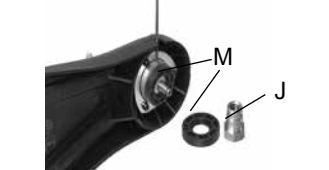
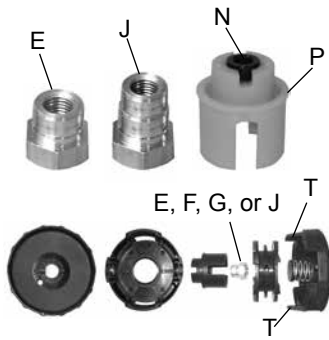
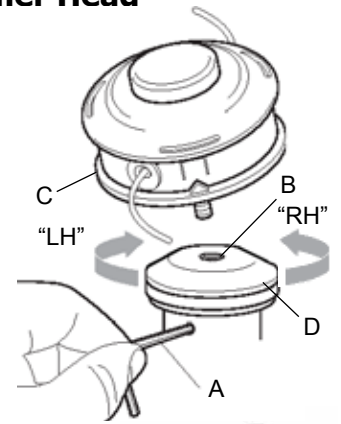

## Loading Instructions

### ENGLISH

#### Speed-Feed® 400 LH/RH Trimmer Head Total Line Capacity

.080 (2.0 mm) dia. – 20' (6 m)

.095 (2.4 mm) dia. – 20' (6 m)

#### Loading Trimmer Line

1. Cut one piece of line to recommended length.
2. Align arrows on top of knob with openings in eyelets.
3. Insert one end of trimmer line into an eyelet, and push line equal distance through trimmer head.
4. Hold trimmer head while turning knob to wind line onto spool until about 5" (13 cm) of each line remains exposed.

**Trimmer head is now fully loaded and ready for operation.**



## Instructions De Chargement

### FRANCAIS

#### Longueur totale capacité de ligne de coupe du taille-bordures

#### Speed-Feed® 400 LH/RH

.080 (2.0 mm) dia. – 20' (6 m)

.095 (2.4 mm) dia. – 20' (6 m)

#### Chargement de la ligne du taille-bordures

1. Couper un morceau de ligne de la longueur préconisée.
2. Aligner les flèches de la partie supérieure du bouton avec les trous des œillets.
3. Insérer une extrémité de la ligne de coupe dans un œillet et pousser la ligne jusqu'à mi-longueur à travers la tête de coupe.
4. Maintenir la tête de coupe en tournant le bouton dans pour enrouler la ligne sur la bobine jusqu'à ce qu'il reste une longueur d'environ 13 cm (5") sortie à chaque extrémité.

**La tête de coupe est à présent complètement chargée et prête pour le fonctionnement.**

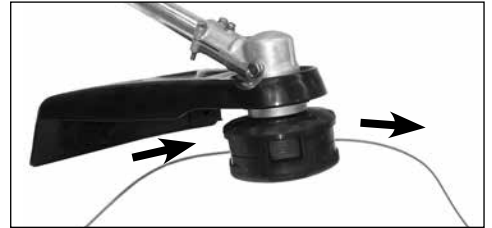

## Instrucciones De Carga

### ESPAÑOL

#### Hilo total capacidad de la cabeza de recortadora

#### Speed-Feed® 400 LH/RH

.080 (2.0 mm) dia. – 20' (6 m)

.095 (2.4 mm) dia. – 20' (6 m)

#### Carga del hilo de la recortadora

1. Corte un pedazo de hilo a la longitud recomendada.
2. Alinee las flechas de la parte superior de la perilla con las aberturas en los ojales.
3. Inserte un extremo del hilo de la recortadora en un ojal, y empuje el hilo una misma distancia por la cabeza de la recortadora.
4. Sujete la cabeza de la recortadora mientras gira la perilla en el carrete hasta que queden al descubierto unos 13 cm (5") de cada hilo.

**La cabeza de la recortadora está ahora completamente cargada y lista para la operación.**

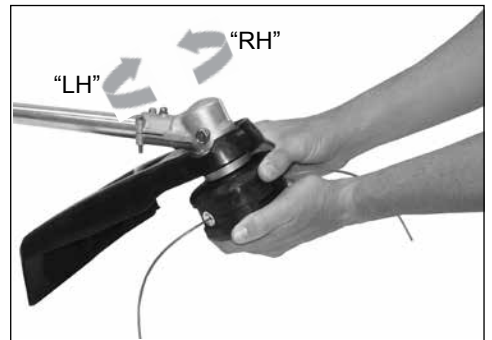

**NOTE:** Trimmer head is pre-wound with .095" (2.4mm) Crossfire™ trimmer line.

**REMARQUE :** Une ligne Crossfire™ de 2,4 mm (0,095") a été pré-enroulée sur la tête de coupe du taille-bordures.

**NOTA:** La cabeza de la recortadora está enrollada de antemano con un hilo de recortadora de 2.4 mm (0.095") Crossfire™.

**IMPORTANT! When the wear indicators located at the bottom of the Speed-Feed® head are worn smooth, or if holes appear, replacement of the cover or the entire Speed-Feed® head is required.**  
**IMPORTANT! Lorsque les indicateurs d'usure placés sous la tête Echo sont complètement usés, il faut remplacer la totalité de la tête.**  
**¡IMPORTANTE! Cuando los indicadores de desgaste ubicados en la parte inferior de la cabeza Speed-Feed® estén lisos por el desgaste, o si aparecen agujeros, será necesario reemplazar la cubierta o toda la cabeza Speed-Feed®.**



**Speed-Feed® LH/RH Trimmer Head Application Chart**  
**Tabella di applicazione LH/RH testina del bordatore**  
**Tabla De Aplicaciones LH/RH De Cabezales**

	MODELS	REF#
ECHO	SRM SERIES: 140, 200, 202, 210, 220, 230, 250, 251, 260, 261, 265, 266, 280, 300, 302, 303, 311, 330, 340, 343, 350, 400, 402, 500, 501, 1500, 1501, 2010, 2090, 2100, 2110, 2200, 2201, 2300, 2301, 2400, 2410, 2450, 2500, 2501, 2502, 2510, 2530, 2601, 3000, 3001, 3010, 3100, 3110, 3400, 3410, 3500, 3550, 3800, 4600	LH6
HOMELITE	HK-24 (to 1/1/86), HK30(after 1/1/86), HK33 (to 1/1/86)	LH2
	BCH20, BCH24, BCH32, BCH33, BCH40, BCH48, HBC-30, HBC-38, HK-15, HK 18 (after 1/1/86), HK-28, HK24(after 1/1/86), HK-25, HK-30 (up to 1/86), HK-33(after 1/1/86), HK-38, PBC-3600, PBC-3800, PBC-4000, PBC-4000, PLT3400, ST-285, ST155, ST175, ST385, ST485	LH4
	FK514, NBA524, PMB522, SX040, SXD40, TXD508	LH3
	HBC40, PBC3800, PBC4000, PMB52, HBC48	LH6
	ST80/385 (EURO)	LH2
	ST100/200/400, SXD20, RK521, TK518	LH4
HONDA	UMK422LNA/LTA, UMK431LNA/TA/UNBA, HHT25SLTAT, HHT-35SLTAT, HHT35SUKAT	LH6
HUSQVARNA	(UP TO 86)16R, 22R, 24R, 25RL	LH2
	24R(up to ser #603702)	LH1
	26LC, 26RLC, 32LC, 32RLC, MONDO	RH1
	122L, 125L, 225L, 225LD, 225R, 225RD, 225RJ, 227LD, 232L, 232R, 322L, 322R, 324LX, 325LX/RX, 326LS/LX, 335LS	LH6
JONSERED	BP40, BP40COMBI, BP2040, BR400, BR420, BR450, BR460, BR480, BR500, Tiger 40, GT21L, GT22L, GT24L, GR26COMBI, GR26D, GR26L, GR32L, GR2026CL, GR2026D, LR200, LR220, LR260, LR320, LR400, LR420, LR450, LR460	LH2
	RS38ANCIEN, RS38 older	LH5
	RS44, GR44, GR41, J40D, KQ20/30 (EURO)	LH6
MARUYAMA	BC184, BC184C, BC200, BC201, BC230, BC241, BC260, BC260H, BC310, BC320, BC320H, BC326, BC340DL, BC402, BC420H, BC500, BC500H, BC2300, BC2321, BC2600, BC3021, BC3200, BC4200H, BCL2550, BCGX22, BCGX31, BCL2250, BCL2250C, BST23, MC-5, NC8	LH2
	BC220DL, BC221DL	LH1
	BT17, BT220, BC200C, BC260C	LH4
	BC184C, BC200C, BC260C	LH6
	BC430DWM, BC440DWM, 32, 35, BC500	LH3
	MAC57, MAC90, MAC95, MAC100A	LH3

McCULLOCH	PROMAC SERIES: III, IIISUP, IVSUP, PROSCAPER; SERIES: 28S, 32H, 32HDS, III IV, V, IS, II, IIHD, SEBIC, SUPMAC100A; PS1, PS2, PS3, PS4, PSS, SEBIV; EB SERIES: III, IVSL, 3, 4, 3SX, 32BCS, 35L, 280, 282, 285BCS, 297BCS, 325BC, 327BC, 2815, 2816 2817, 2818	LH6
	MAC 22/23/30A, SUPERMAC 30AV, MS33, DELTA, 38AV, MS40, BP30AV, TD2400/3300/4000	LH2
	MAC 57, MAC 90, MAC 95, MAC 100A, MAC 32, MAC 37	LH3
RED MAX	BC220DL, BC221DL, BC300DL, BC2300DL, BK235FL, BK345FL, BK435FL, BK530DL, BC17, BC23, BC32, BC240DL LH1	LH1
	BC260DL, BC261DL, BC262DL, BC340DL, BC341DL, BC342DL, BC2600DL, BC430DWM, BC440DWM, BK346FL, BK245FLK, BK436FL, BC245A, BC260DM/DMU, BC340DWM/FW, BC431DWM, BCD20, BCF01, BC2601S, BC3400DW, BC4400DW, BCX2600DS, BC22500S/SU/SW	LH2
	BC430DWM, BC440DWM, BC441DWM, BC442DWM, BC531DWM, BC532DWM, FBC22, FBC26 LH3	LH3
	BC200, BC2000DL, BT2000, BT2001DL	LH6
SHINDAIWA	22T, C230, C242, C2510, T195s, T220, T222, T230, T231, T230s, T242, C242, T242X, T2510, C2510, T2510X	LH1
	C3410, T3410, C260, T260, T261, T261B/XR/XB, T270, T272, T272X, T282, C282, T300, T3410, T3410X, T350	LH2
	BP35, B45, B450, C350	LH3
	T235, T344, C344, T254, C254	LH6
STIHL	FS51, FS55, FS60, FS61, FS65, FS80, FS83, FS85, FS86, FS90, FS91, FS96	LH2
	FS66, FS74, FS76, FS81, FS83, FS85, FS86, FS100, FS106, FS108, FS110, FS130, FS250, FS44, FS45, FS46, FS48, FS52, FS56, FS62, FS66, FS85, FS86, FS88, FS96, FS106, FS108, FS120, FS200, FS350, FS450, FS550	LH5
DOLMAR / SACHS DOLMAR	BC250, BC330, BC400, PRO370, PRO400, SD330, LT250	LH2

	REF#
<b>ECHO</b> GT series 100, 140, 160, 200, 225, 225i, 230, 251, 1000, 1100, 2000, 2100, 2101, 2102, 2103, 2200, 2301, 2400	<b>RH1</b>
<b>HOMELITE</b> HBC20, HBC24, HBC32C, HBC33, ST200, ST360, ST80, SXD20, TK518, RK521, ST100, ST120, ST155, ST175CG	<b>RH2</b>
<b>HUSQVARNA</b> 26LC, 26RLC, 32LC, 32RLC, MONDO	<b>RH1</b>
<b>JONSERED</b> GT25L, GT26, GT26L	<b>RH1</b>

<b>MARUYAMA</b> BC201C	<b>RH2</b>
<b>McCULLOCH</b> 70,75,80,85,MAC100A, MAC85, MAC2825, MAC2827, PROMAC, SER:I-SX, II, II SUP, IV, HD, 2320L, 2035,2045, 138, SEB-I SX, SPECIAL, SEB II-S, SEB III-S, SILVER EAGLE 28, SILVER EAGLE 32, SUPER EBI-S, TITAN, 2100, 2200, 2510, ROADRUNNER,	<b>RH1</b>
<b>SHINDAIWA</b> F18, F20, F21, F222, F230, F195	<b>RH2</b>

**Left Hand Thread Trimmer Units**

**Straight Shaft Trimmers**

All  
LH



Noire  
Black  
Negro  
Moyeu

Base Central

Core

Reference #

**LH1**

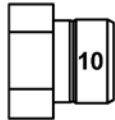

10 mm x 7mm



Gold

Color  
Gold  
Oro, Or

Reference #

**LH2**

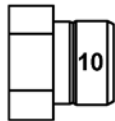

10 mm x 8 mm



Silver

Color  
Gold  
Oro, Or

Reference #

**LH3**

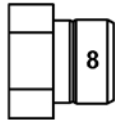

8 mm x 10 mm



Silver

Color  
Red  
Rouge, Rojo

Reference #

**LH4**

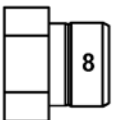

8 mm-1.25 mm

Color  
Red  
Rouge, Rojo

Reference #

**LH5**

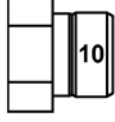

10 mm-1.0mm

Color  
Green  
Vert, Verde

Reference #

10 mm-1.25 mm

**LH6**

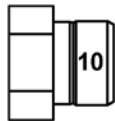

Silver  
Argent, Plata

Color  
Gold  
Oro, Or

**Right Hand Thread Trimmer Units**

**Curved Shaft Trimmers**

All  
RH

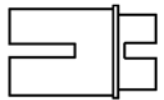

Blanc  
White  
Blanco  
Moyeu

Base Central

Core

Reference #

**RH1**

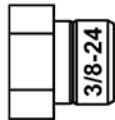

3/8-24 RH

Color  
Black  
Noire, Negro

Reference #

**RH2**

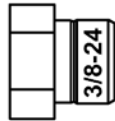

3/8-24 x 8 mm RH

Color  
Black  
Noire, Negro

Black  
Noire, Negro